



General Installation Guide

Proprietary and Confidential

Table of Contents

OBC9000S™ Installation Kit Contents.....	4
Introduction to GPS.....	6
Safety Statement.....	6
Additional Support.....	6
Tool List.....	7
Selecting the Mounting Location for the OBC9000S™	8
Selecting the Mounting Location for the Reporting Switch.....	8
Selecting the “Smart” GPS Antenna Location.....	8
Locating Vehicle Power.....	9
Powering the Unit for the First Time.....	9
Using the Reporting Swtich Feature	10
Congratulations	10
OBC9000S™ Wiring Diagram.....	11

Proprietary and Confidential

OBC9000S™

by On-Board Communications, Inc.



Thank you for selecting the OBC9000S™ Wireless Tracking, Monitoring and Remote Control, Vehicle Management Solution. The OBC9000S™ is designed to provide efficient, affordable, nationwide vehicle tracking.

This guide describes how to install, activate and use your OBC9000S™ unit. Following the instructions in this guide will enable you to get your unit operating quickly and easily. In the event that you require additional assistance, please contact customer support via e-mail at support@obccom.com or contact us at the address or contact number below:

On-Board Communications, Inc.
Attn: Customer Support
12720 Hillcrest Road
Dallas, TX 75230
877-340-0300 ext. 290

CAUTION: On-Board Communications, Inc. is not responsible for damages to any vehicle due to OBC9000S™ unit installation.

Notes:

- **Failure to install the OBC9000S™ unit in accordance with these instructions may result in damage to the vehicle and may void the unit's warranty.**
- **Read all instructions before attempting installation.**

Proprietary and Confidential

OBC9000S™ Installation Kit Contents



OBC9000™



**Smart GPS Antenna with
Magnetic Base & 9ft. Cable**



Push Button Switch with Red and Green Indicator Lights

Proprietary and Confidential

OBC9000S™

by On-Board Communications, Inc.



Electrical Connections / Mounting Kit:

- 4 Small Cable Ties
- 1 #10 Ring Terminal
- 4 Posi-Tap™ Connectors
- 2 128" Female Quick-disconnect
- 2 Mini Fuse-Tap Connectors
- 2 22AWG – 18AWG Butt splice connector
- 1 6 ft. 5 wire, Power Cable w/Connector
- 1 2" x 3" Velcro™ Self-Adhesive Strip
- 1 2" x 1 ½" Velcro™ Self-Adhesive Strip
- 2 Isopropyl Alcohol Swabs

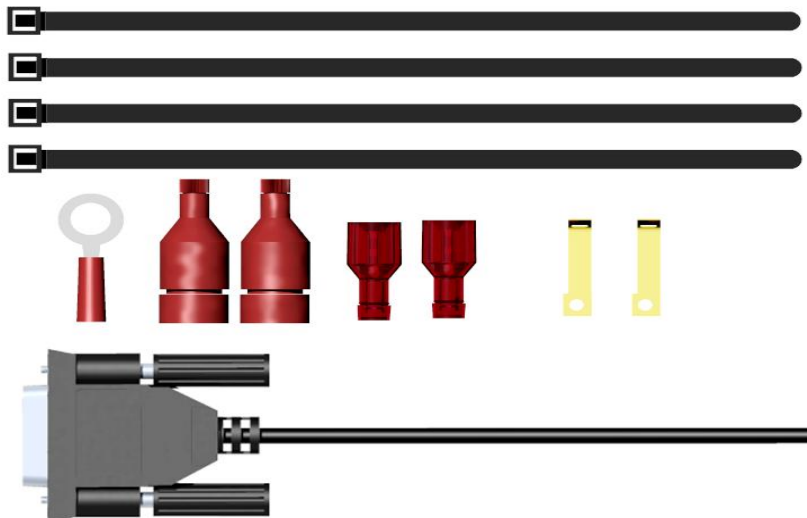

Proprietary and Confidential

Introduction to GPS

Satellites are in a 12-hour orbit at 12,000 miles above the earth. There are 24 satellites in the system and generally there are at least 5 satellites orbiting overhead at any one time. This antenna must be positioned to receive signals from these satellites. The antenna location must be selected carefully so that the antenna can receive the satellite signals. The standard GPS antenna is designed to be located inside the vehicle. The ideal location is in a place that allows line of sight reception from the GPS satellites in orbit above. The satellite signals will pass through glass. Both the radio transceiver antenna and GPS antenna are designed to be mounted inside the vehicle, (not exposed to the outside weather).

Safety Statement

This guide covers the installation of the OBC9000S™ to ensure a safe and functional install of the unit by either a professional or novice installer.

- **Before attempting to add anything electrical to your vehicle, refer to the Owner's Manual for additional information.**
- **Always disconnect the vehicle battery while installing this or any other automotive electronic product.**
- **Make sure the unit and all associated cables are securely mounted and do not impede any of the vehicle's controls. Do not mount the unit near brake and gas pedals.**
- Use care when routing the unit's cables. Route the cables where they will be protected. Use commonly accepted install practices for after-market automotive electronic devices. Here are three acceptable methods of making a wire connection:
 - Soldering your connections (recommended)
 - Crimp connectors (with the use of the proper crimping tool)
 - Posi-Tap™ Connectors (no tools required)

Regardless of the method you choose, ensure that the connection is mechanically sound and properly insulated. Use high quality electrical tape and shrink tubing where necessary.

This product is connected directly to the vehicle's 12-volt system. There is no on-off switch on the unit. The installed device operates 24 hours a day and must be energized to log vehicle events or send data as required by anyone using the service.

Additional Support

- Over the phone Support is available.

Proprietary and Confidential

Tool List

- Power drill AC/DC (Cordless recommended)
- Magnetic bit holder that houses Phillips and flat-head bits
- Wire stripper and cutters
- Crimpers for insulated connectors
- Electronic voltage meter (Digital display recommended)
- Tools to disconnect and reconnect vehicle battery (Crescent wrench, open end wrenches, etc.)
- Tools to remove internal vehicle trim (Panel poppers, sockets, ratchet, screwdrivers, torx bits, hex bits, etc.)
- Ring terminal connectors (For grounding wire)
- Self tapping screws (Various sizes)
- Star washers for grounding (Strongly recommended)
- Electrical tape (Black)
- Wire 20 gauge
- Velcro and/or double sided tape
- Wire ties (Various sizes)
- Soldering iron & solder

Using Your Digital Multi Meter

On-Board Technical Support hears more and more often about damaged computers and airbag systems as a result of probing with a test light. Not all air bag wires are in yellow tubing, and not all transistorized outputs can light a test light bulb without shorting out! The best solution, as it has always been, is a good digital multi meter.

How to Find (+) 12VDC Ignition with Your Multi Meter

1. Set your meter to DCV or DC voltage (12VDC or 20VDC is fine)
2. Attach the (-) probe of the meter to chassis ground.
3. Probe the wire you suspect of being the ignition wire. The steering column is an excellent place to find this wire. Your meter should read (+) 0V.
4. Turn the ignition key to the "ON" position. If your meter reads (+)12VDC, go to the next step. If it doesn't, probe another wire.
5. Now turn the key to the start position. The meter display should stay steady (+) 12V, not dropping by more than a few tenths of a volt. If it drops close to or all the way to zero, go back to step 3. If it stays steady at (+) 12VDC you have the ignition wire.

Proprietary and Confidential

OBC9000S™

by On-Board Communications, Inc.



Selecting the Mounting Location for the OBC9000S™

The OBC9000S™ and the cables that connect to it must be mounted so it will:

- Not be exposed to damage from people or objects
- Not impede any of the vehicle's operational systems such as steering, brake or gas pedals

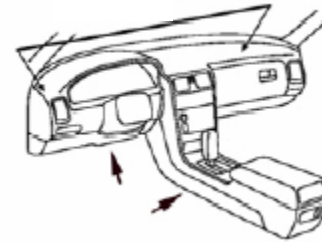

In addition, the OBC9000S™ unit itself must not be exposed to direct sunlight or excessive heat generated by the vehicle's operation.

A flat surface is recommended for the unit's placement. The installation Velcro is designed to hold the unit in place; however additional mounting items may be needed to help secure the unit if a flat surface is not available. Do not hang the unit from the installation Velcro without additional mounting hardware as vibration from the vehicle's use will cause the unit to fall.

Some examples of mounting locations include: under the dash above the knee bolster, under the center console, behind the glove compartment, and in the trunk.

Selecting the Mounting Location for the Reporting Switch

The OBC9000S™ Reporting Switch may be mounted to any flat surface on the lower dash or console.

Selecting the Smart GPS Antenna Location

The OBC9000S™ requires two antenna elements. One antenna is for receiving GPS signals from The Navistar GPS satellites. The second antenna is a radio transceiver antenna that communicates with the ReFLEX network. The antenna does not require a ground plane to function properly. There is one antenna cable in addition to the main power harness that must be connected to the OBC9000S™, so be sure there is room to access the connectors for installation and service.

The GPS antenna must be mounted flat with the GPS Receiver faced up. The ideal location is under the dashboard. It can be placed under the dash pad as long as the pad or covering is not metallic or a barrier to the GPS satellite signals.

Proprietary and Confidential

OBC9000S™

by On-Board Communications, Inc.



If the vehicle window has a solid dark coating around the edge, do not place the GPS antenna behind the coating. The GPS signals will travel through the clear glass but will be reduced if the window has any metallic coating or tint applied.

The GPS antenna will work best if it has a clear view to the sky and as much of the horizon as possible. Any metallic objects between the antenna and the satellites will degrade the signal and reduce the overall performance.

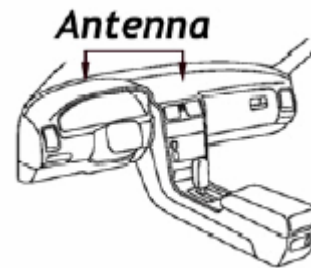

Locating Vehicle Power

The OBC9000S™ has an internal power management program that monitors the vehicle power at all times. The internal power management program is continuously looking at the condition of the vehicle battery in order to detect the state of the vehicle operation. Possible sources besides the direct connection to the battery are the main fuse block panel or the point where the vehicle charging circuits are connected to the 12-volt system.

Connect the red lead to the +12VDC vehicle power. The power cable can be shortened if needed. Connect the black lead to the vehicle chassis (ground). Connect the yellow lead to the Ignition/Switched +12VDC power. Connect the blue lead to the white lead coming from the push button switch. The green lead is used in conjunction with a “starter kill” relay harness available as an option from On-Board Communications. The red lead and the black lead on the push button switch are also connected to +12VDC and chassis ground respectively.

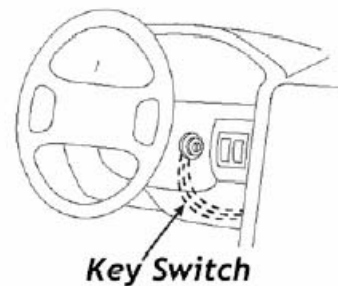

***Improper connection could result in numerous “Reboot” notifications, and increased usage on monthly billing.**

Powering the Unit for the First Time

After you have wired in the power harness to the vehicle, connect the GPS antenna cable and the power harness cable to the OBC9000S™. Once the power harness cable is attached the RED Led will flash at a rate of 1 second “on” and 1 second “off” while the unit scans for the ReFLEX signal. Within five minutes the flash rate will change to approximately 1 second “on” and 3 seconds “off”. This will indicate the unit is operating in it’s normal mode. Also, within 5 minutes of the GPS antenna cable being attached, the GREEN Led will come on and stay on indicating the unit has established a GPS location or “lock”. The Green Led will appear to dim when the Red turns on but it should not go completely off.

Proprietary and Confidential

Using the Reporting Switch Feature

The OBC9000S™ Reporting Switch allows the vehicle to disconnect from the system and stop all tracking reports. Once the OBC9000S™ indicates it is operating in its normal mode, the reporting switch will either have the green LED or the red LED lit. The button will toggle the LED back and forth. When the green LED is lit – the unit is operating normally and sending in all tracking reports. When the red LED is lit – the unit will not send in any tracking reports.

Congratulations!

You have just installed the OBC9000s™ Internet based vehicle location system with Reporting Switch Capabilities.

Please record the following information:

- **Capcode ID # (located on the back of the OBC9000s™- This is the 9 digit number located just above the words “USA Mobility”)**
-

Now that the unit is installed, here is how to use the system. Turn on your computer and log on to the Internet using your standard Internet browser. Go to the AutoTraks™ login page at www.autotraks.com. Enter the customer login id and password and click the login button.

You are now at the Fleet Information Summary page. From the Selected Unit drop menu box at the top of the page, select the vehicle to be tested. Click the “Find Unit” tab and select “Get Current Location” button. Click the “Find” tab and then click the “Send” tab. The site will automatically redirect you back to the Fleet Information Summary page and you will notice a small envelope next to the vehicle you chose. Within 2 minutes, the vehicle should appear at the top of the page with new information. Please note – you may need to refresh your screen in order to see this information. To refresh the screen, move the mouse to the top of the page and click on the On-Board logo. Do not use the refresh button on your Internet browser as this may not display the new information depending upon how your browser is configured.

Once you receive a position report back from the unit – it is functioning properly.

Proprietary and Confidential

OBC9000™ Wiring Diagram

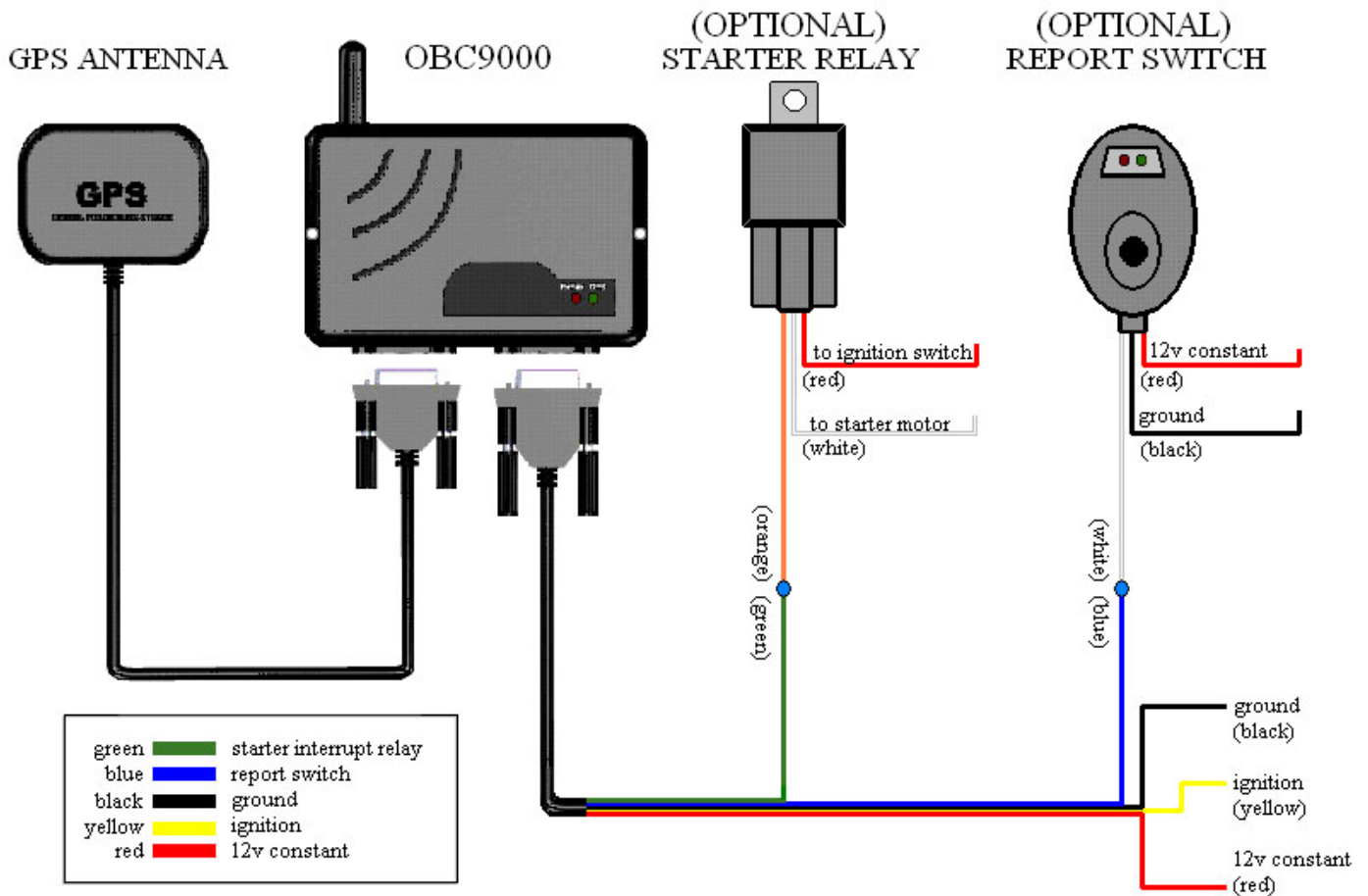

Proprietary and Confidential